

Model Name			PUHZ-SHW112VAA(-BS)	PUHZ-SHW112YAA(-BS)
Power supply (phase, cycle, voltage)			1φ, 230V, 50Hz	3φ, 400V, 50Hz
	Max. current	A	28.0	13.0
Breaker size			32.0	16.0
Outer casing			Galvanized plate	Galvanized plate
External finish			Munsell: N8.75 Munsell N2.75 (FRONT PANEL)	Munsell: N8.75 Munsell N2.75 (FRONT PANEL)
Refrigerant control			Linear expansion valve	Linear expansion valve
Compressor			Hermetic scroll	Hermetic scroll
	Model		DNK28FBAMT	DNK28FBBMT
	Motor output	kW	2.2	2.2
Start type			Inverter	Inverter
Protection devices			HP switch LP switch Discharge thermo Overcurrent detection Comp. surface thermo	HP switch LP switch Discharge thermo Overcurrent detection Comp. surface thermo
	Oil (Model)	L	1.00 (FVC68D)	1.00 (FVC68D)
Crankcase heater			W	-
Heat exchanger		Air	Plate fin coil	Plate fin coil
		Water	-	-
Fan	Fan(drive) x No.		Propeller fan x 1	Propeller fan x 1
	Fan motor output	kW	0.2	0.2
	Air flow	m ³ /min (CFM)	50 (1,760)	50 (1,760)
Defrost method			Reverse cycle	Reverse cycle
Noise level (SPL)	Heating	dB(A)	47	47
	Cooling	dB(A)	49	49
Noise level (PWL)	Heating	dB(A)	60	60
Dimensions	Width	mm(in)	1050 (41-5/16)	1050 (41-5/16)
	Depth	mm(in)	480 (18-7/8)	480 (18-7/8)
	Height	mm(in)	1020 (40-3/16)	1020 (40-3/16)
Weight		kg(lbs)	116 (256)	128 (282)
Refrigerant (GWP)			R410A (1975)	R410A (1975)
	Quantity	kg(lbs)	4.6 (10.1)	4.6 (10.1)
Pipe size O.D.	Liquid	mm(in)	9.52 (3/8)	9.52 (3/8)
	Gas	mm(in)	15.88 (5/8)	15.88 (5/8)
Connection method			Flared	Flared
Between the indoor & outdoor unit	Height difference	m	Max. 30	Max. 30
	Piping length	m	2 to 75	2 to 75
Guaranteed operating range (Outdoor)	Heating	°C	-28 to +21	-28 to +21
	DHW	°C	-28 to +35	-28 to +35
	Cooling*	°C	-15 to +46	-15 to +46
Outlet water temp. (Max in heating, Min in cooling)	Heating	°C	+60	+60
	Cooling	°C	+5	+5
Nominal return water temperature range	Heating	°C	+5 to +59	+5 to +59
	Cooling	°C	+8 to +28	+8 to +28
Water flow rate range		L/min	14.4 to 32.1	14.4 to 32.1

* Optional air protection guide is required where ambient temperature is lower than -5°C.
The temperature is 10°C when the unit is connected with Cylinder unit or Hydrobox.
For more details, refer to "Cylinder unit / Hydrobox".

Model name		PUHZ-SHW112VAA(-BS)	PUHZ-SHW112YAA(-BS)	
Nominal water flow rate (Heating mode)		L/min	32.1	32.1
Heating (A7/W35)	Capacity	kW	11.2	11.2
	COP		4.46	4.46
	Power input	kW	2.51	2.51
Heating (A2/W35)	Capacity	kW	11.2	11.2
	COP		3.22	3.22
	Power input	kW	3.48	3.48
Pressure difference (water circuit)		kPa	-	-
Heating pump input (based on EN14511)		kW	-	-
Nominal water flow rate (Cooling mode)		L/min	28.7	28.7
Cooling (A35/W7)	Capacity	kW	10.0	10.0
	EER (COP)		2.83	2.83
	Power input	kW	3.53	3.53
Cooling (A35/W18)	Capacity	kW	10.0	10.0
	EER (COP)		4.74	4.74
	Power input	kW	2.11	2.11
Pressure difference (water circuit)		kPa	-	-
Cooling pump input (based on EN14511)		kW	-	-
Recommended plate heat exchanger			MWA2-38PA	MWA2-38PA

The table shows performance data obtained when a plate heat exchanger is connected.

■ Inverter multi

Model name		PUMY-P112V/YKM(E)3(-BS)	PUMY-P125V/YKM(E)3(-BS)	PUMY-P140V/YKM(E)3(-BS)	
Nominal water flow rate (Heating mode)		L/min	35.8	35.8	35.8
Heating (A7/W35)	Capacity	kW	12.5	12.5	12.5
	COP*		4.08	4.08	4.08
	Power input	kW	3.06	3.06	3.06
Heating (A2/W35)	Capacity	kW	10.0	10.0	10.0
	COP*		2.86	2.86	2.86
	Power input	kW	3.50	3.50	3.50
Pressure difference (water circuit)		kPa	-	-	-
Heating pump input (based on EN14511)		kW	-	-	-
Recommended plate heat exchanger			MWA2-38-PA-4	MWA2-38-PA-4	MWA2-38-PA-4

The table shows performance data obtained when a plate heat exchanger is connected.

* In case of ATW unit single connection, the COP for ATW heating decreases depending on the number of connected ATA units (Refer to the figure below).

ATW COP reduction ratio by ATA indoor units

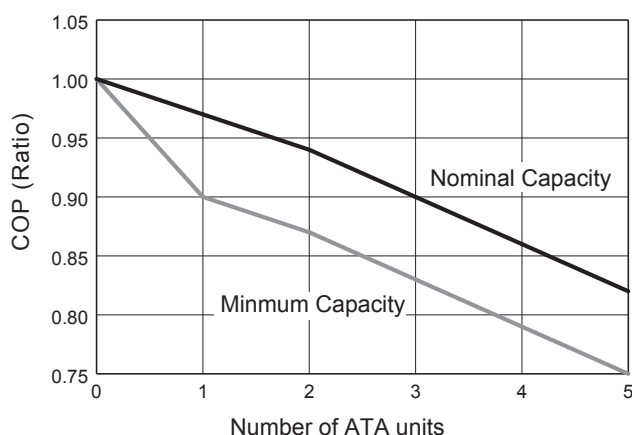

	0	1	2	3	4	5
Nominal Capacity	1.00	0.97	0.94	0.90	0.86	0.82
Minimum Capacity	1.00	0.90	0.87	0.83	0.79	0.75

■Zubadan

- PUHZ-SHW80/112VHA(-BS)**
- PUHZ-SHW112/140YHA(-BS)**
- PUHZ-SHW230YKA2**

- PUHZ-SHW80/112VAA(-BS)**
- PUHZ-SHW80/112YAA(-BS)**

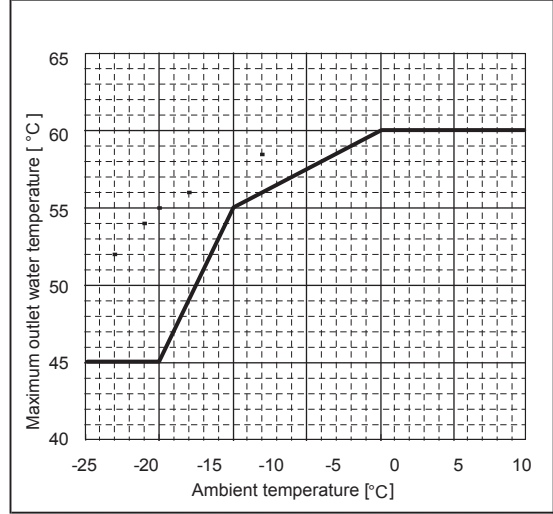
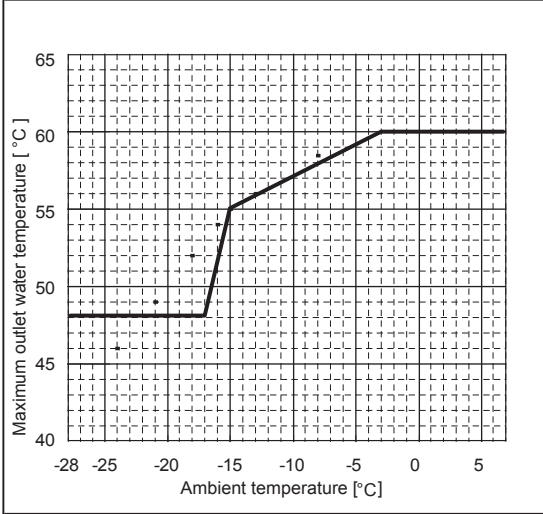

*PUHZ-SHW80/112/140 Service reference number from "R2": down to -28°C
Before "R2" and PUHZ-SHW230 : down to -25°C

■Inverter multi

- PUMY-P112/125/140VKM3(-BS)**
- PUMY-P112/125/140YKM3(-BS)**
- PUMY-P112/125/140YKME3(-BS)**

Maximum outlet water temperature curve at single operation of ATW Heating

Maximum outlet water temperature curve at simultaneous operation of ATA Heating and ATW heating

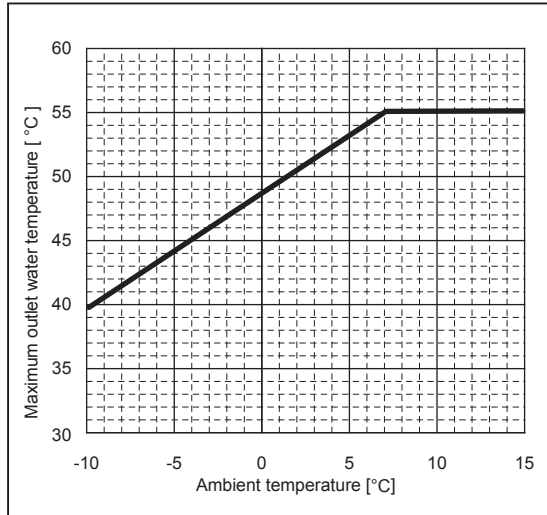
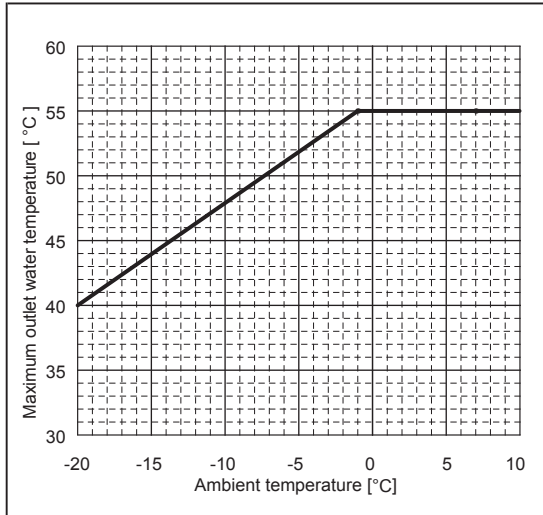

- PUAZ-SW75/100VAA(-BS)
- PUAZ-SW75/100YAA(-BS)
- PUAZ-SHW80/112VAA(-BS)
- PUAZ-SHW80/112YAA(-BS)

Unit : mm

Outdoor unit

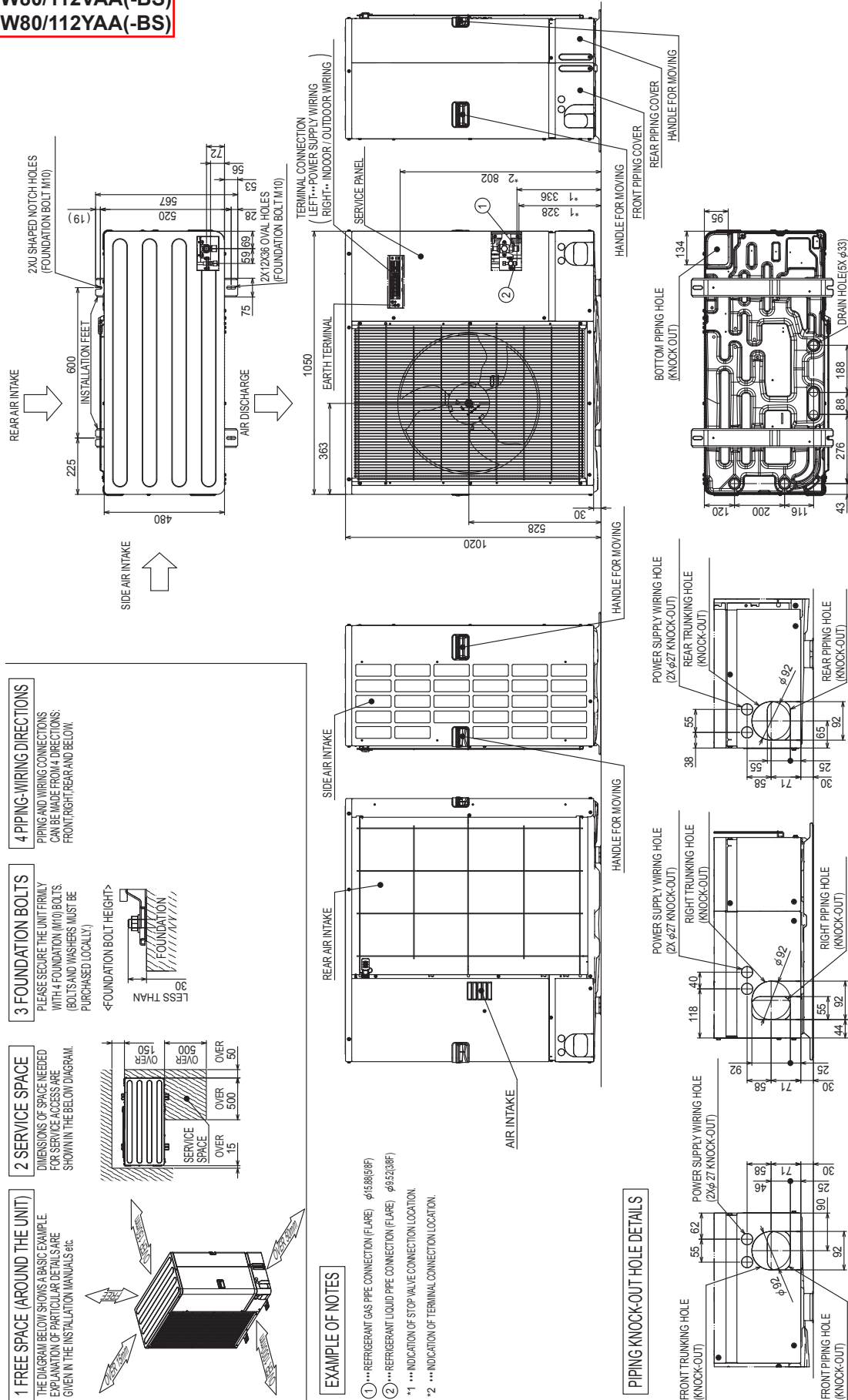

■ PUIZ-SHW80V/YAA(-BS)

Water outlet temperature[°C]		25		35		40		45		50		55		60	
Ambient temperature[°C]		Capacity	COP	Capacity	COP	Capacity	COP	Capacity	COP	Capacity	COP	Capacity	COP	Capacity	COP
Max	(INJ) -20	-	-	7.3	2.23	7.0	1.94	6.8	1.68	-	-	-	-	-	-
	(INJ) -15	-	-	8.7	2.63	8.4	2.30	8.0	2.00	7.7	1.84	7.4	1.59	-	-
	(INJ) -10	10.8	3.65	10.2	3.04	9.9	2.64	9.5	2.28	9.2	1.98	8.8	1.71	-	-
	(INJ) -7	9.7	3.99	9.2	3.32	8.9	2.88	8.6	2.49	8.3	2.16	8.0	2.02	-	-
	(INJ) 2	9.4	4.09	8.9	3.41	8.6	2.96	8.3	2.71	8.0	2.49	7.7	2.15	7.4	1.86
	7	9.9	5.36	9.3	4.47	9.0	3.87	8.7	3.35	8.4	2.90	8.1	2.69	7.7	2.17
	12	11.6	6.29	10.9	5.24	10.6	4.54	10.2	3.93	9.9	3.40	9.5	2.94	9.1	2.55
	15	12.6	6.87	11.9	5.72	11.5	4.96	11.1	4.29	10.7	3.72	10.3	3.21	9.9	2.78
20	14.5	7.95	13.7	6.63	13.3	5.74	12.8	4.97	12.4	4.30	11.9	3.72	11.4	3.22	
Nominal	(INJ) -20	-	-	7.3	2.23	7.0	1.94	6.8	1.68	-	-	-	-	-	-
	(INJ) -15	-	-	8.0	2.74	8.0	2.38	8.0	2.00	7.7	1.84	7.4	1.59	-	-
	(INJ) -10	8.0	3.52	8.0	2.93	8.0	2.55	8.0	2.26	8.0	1.96	8.0	1.70	-	-
	(INJ) -7	8.0	4.17	8.0	3.48	8.0	3.02	8.0	2.68	8.0	2.33	8.0	2.02	-	-
	(INJ) 2	8.0	4.26	8.0	3.55	8.0	3.20	8.0	2.85	8.0	2.49	7.7	2.15	7.4	1.86
	7	8.0	5.58	8.0	4.65	8.0	4.05	8.0	3.42	8.0	3.12	8.0	2.70	7.7	2.17
	12	8.0	6.54	8.0	5.45	8.0	4.74	8.0	4.20	8.0	3.65	8.0	3.16	8.0	2.78
	15	8.0	7.14	8.0	5.95	8.0	5.18	8.0	4.58	8.0	3.99	8.0	3.45	8.0	3.03
20	8.0	8.15	8.0	6.79	8.0	5.91	8.0	5.23	8.0	4.55	8.0	3.94	8.0	3.46	
Mid	-20	-	-	5.8	2.42	5.6	2.10	5.4	1.86	-	-	-	-	-	-
	-15	-	-	6.4	2.95	6.4	2.57	6.4	2.27	6.4	1.98	6.4	1.71	-	-
	-10	6.4	3.87	6.4	3.22	6.4	2.80	6.4	2.48	6.4	2.16	6.4	1.87	-	-
	-7	6.4	4.34	6.4	3.62	6.4	3.15	6.4	2.79	6.4	2.42	6.4	2.10	-	-
	2	6.4	4.43	6.4	3.70	6.4	3.21	6.4	2.85	6.4	2.48	6.4	2.14	6.4	1.88
	7	6.4	5.65	6.4	4.71	6.4	4.10	6.4	3.63	6.4	3.16	6.4	2.73	6.4	2.40
	12	6.4	6.47	6.4	5.39	6.4	4.69	6.4	4.15	6.4	3.61	6.4	3.13	6.4	2.75
	15	6.4	6.97	6.4	5.81	6.4	5.06	6.4	4.47	6.4	3.89	6.4	3.37	6.4	2.96
20	6.4	8.04	6.4	6.70	6.4	5.83	6.4	5.16	6.4	4.49	6.4	3.88	6.4	3.42	
Min	-20	-	-	5.0	2.37	4.8	2.06	4.7	1.78	4.5	1.54	-	-	-	-
	-15	-	-	5.7	2.68	5.5	2.32	5.3	2.01	5.1	1.74	4.9	1.51	-	-
	-10	3.7	3.42	3.5	2.85	3.4	2.47	3.2	2.14	3.1	1.85	3.0	1.60	-	-
	-7	3.8	3.53	3.6	2.94	3.5	2.55	3.4	2.21	3.2	1.91	3.1	1.65	-	-
	2	3.9	4.56	3.7	3.80	3.6	3.29	3.5	2.85	3.3	2.47	3.2	2.13	3.1	1.85
	7	3.6	5.38	3.4	4.48	3.3	3.89	3.2	3.36	3.1	2.91	3.0	2.52	2.8	2.18
	12	4.3	6.38	4.1	5.32	4.0	4.61	3.8	3.99	3.7	3.45	3.6	2.99	3.4	2.58
	15	4.7	6.92	4.5	5.77	4.3	5.00	4.2	4.33	4.0	3.74	3.9	3.24	3.7	2.80
20	5.4	8.00	5.1	6.67	5.0	5.78	4.8	5.00	4.6	4.33	4.4	3.74	4.3	3.24	

■ PUIZ-SHW112V/YAA(-BS)

Water outlet temperature[°C]		25		35		40		45		50		55		60	
Ambient temperature[°C]		Capacity	COP	Capacity	COP	Capacity	COP	Capacity	COP	Capacity	COP	Capacity	COP	Capacity	COP
Max	(INJ) -20	-	-	10.2	2.02	10.0	1.79	9.7	1.57	-	-	-	-	-	-
	(INJ) -15	-	-	11.9	2.30	11.6	2.04	11.2	1.80	10.8	1.56	10.4	1.35	-	-
	(INJ) -10	12.8	2.34	12.2	2.12	11.9	2.13	11.5	2.13	11.2	2.01	10.8	1.74	-	-
	(INJ) -7	12.8	2.62	12.2	2.37	11.9	2.38	11.5	2.39	11.2	2.25	10.8	1.95	-	-
	(INJ) 2	12.3	2.62	11.7	3.16	11.4	2.87	11.2	2.60	10.8	2.25	10.4	1.94	9.9	1.68
	7	13.9	4.88	13.1	4.07	12.7	3.52	12.3	3.05	11.8	2.64	11.4	2.70	10.9	1.98
	12	16.1	5.50	15.2	4.58	14.7	3.97	14.2	3.44	13.7	2.98	13.2	2.57	12.6	2.23
	15	17.4	5.86	16.4	4.88	15.9	4.23	15.4	3.66	14.8	3.17	14.3	2.74	13.7	2.37
20	19.9	6.46	18.8	5.39	18.2	4.67	17.6	4.04	17.0	3.50	16.3	3.03	15.6	2.62	
Nominal	(INJ) -20	-	-	10.2	2.02	10.0	1.79	9.7	1.57	-	-	-	-	-	-
	(INJ) -15	-	-	11.2	2.37	11.2	2.05	11.2	1.80	10.8	1.56	10.4	1.35	-	-
	(INJ) -10	11.2	3.57	11.2	2.98	11.2	2.58	11.2	2.26	11.2	2.01	10.8	1.74	-	-
	(INJ) -7	11.2	4.01	11.2	3.34	11.2	2.89	11.2	2.54	11.2	2.25	10.8	1.95	-	-
	(INJ) 2	11.2	3.86	11.2	3.22	11.2	2.90	11.2	2.60	10.8	2.25	10.4	1.94	9.9	1.68
	7	11.2	5.35	11.2	4.46	11.2	3.87	11.2	3.39	11.2	3.01	11.2	2.71	10.9	1.98
	12	11.2	6.56	11.2	5.46	11.2	4.74	11.2	4.15	11.2	3.68	11.2	3.32	11.2	2.84
	15	11.2	7.26	11.2	6.05	11.2	5.24	11.2	4.60	11.2	4.08	11.2	3.67	11.2	3.14
20	11.2	8.47	11.2	7.06	11.2	6.12	11.2	5.37	11.2	4.76	11.2	4.29	11.2	3.67	
Mid	(INJ) -20	-	-	8.2	2.14	8.0	1.89	7.7	1.66	-	-	-	-	-	-
	(INJ) -15	-	-	9.0	2.51	9.0	2.17	9.0	1.90	8.6	1.65	8.3	1.43	-	-
	(INJ) -10	9.0	3.78	9.0	3.15	9.0	2.73	9.0	2.39	9.0	2.12	8.6	1.84	-	-
	(INJ) -7	9.0	4.24	9.0	3.53	9.0	3.06	9.0	2.68	9.0	2.38	8.6	2.06	-	-
	(INJ) 2	9.0	4.09	9.0	3.41	9.0	3.07	9.0	2.75	8.6	2.38	8.3	2.06	8.0	1.78
	7	9.0	5.66	9.0	4.72	9.0	4.09	9.0	3.59	9.0	3.18	9.0	2.86	8.7	2.09
	12	9.0	6.94	9.0	5.16	9.0	4.48	9.0	3.87	9.0	3.35	9.0	2.90	9.0	2.51
	15	9.0	7.68	9.0	5.71	9.0	4.95	9.0	4.29	9.0	3.71	9.0	3.21	9.0	2.77
20	9.0	8.97	9.0	6.67	9.0	5.78	9.0	5.01	9.0	4.33	9.0	3.75	9.0	3.24	
Min	-20	-	-	5.0	2.37	4.8	2.06	4.7	1.78	4.5	1.54	-	-	-	-
	-15	-	-	5.7	2.68	5.5	2.32	5.3	2.01	5.1	1.74	4.9	1.51	-	-
	-10	3.7	3.42	3.5	2.85	3.4	2.47	3.2	2.14	3.1	1.85	3.0	1.60	-	-
	-7	3.8	3.53	3.6	2.94	3.5	2.55	3.4	2.21	3.2	1.91	3.1	1.65	-	-
	2	3.9	4.56	3.7	3.80	3.6	3.29	3.5	2.85	3.3	2.47	3.2	2.13	3.1	1.85
	7	3.6	5.38	3.4	4.48	3.3	3.89	3.2	3.36	3.1	2.91	3.0	2.52	2.8	2.18
	12	4.3	6.38	4.1	5.32	4.0	4.61	3.8	3.99	3.7	3.45	3.6	2.99	3.4	2.58
	15	4.7	6.92	4.5	5.77	4.3	5.00	4.2	4.33	4.0	3.74	3.9	3.24	3.7	2.80
20	5.4	8.00	5.1	6.67	5.0	5.78	4.8	5.00	4.6	4.33	4.4	3.74	4.3	3.24	

Outdoor unit

PUHZ-SHW112V/YAA(-BS)

■ Water outlet temperature 35 [°C]

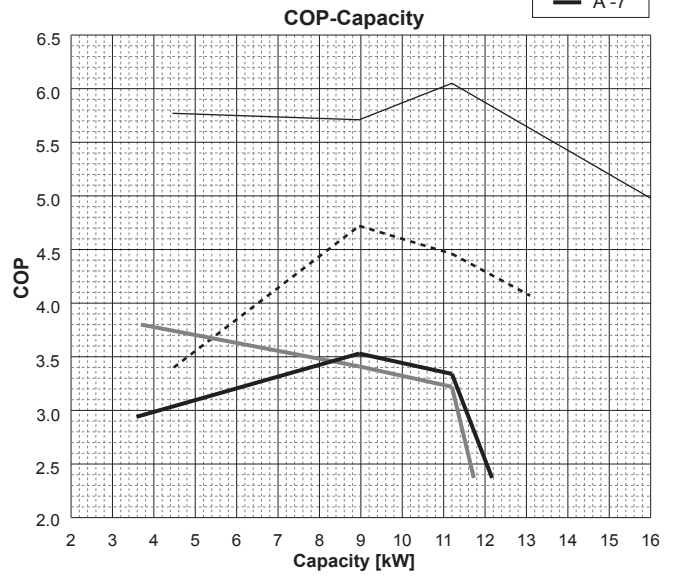
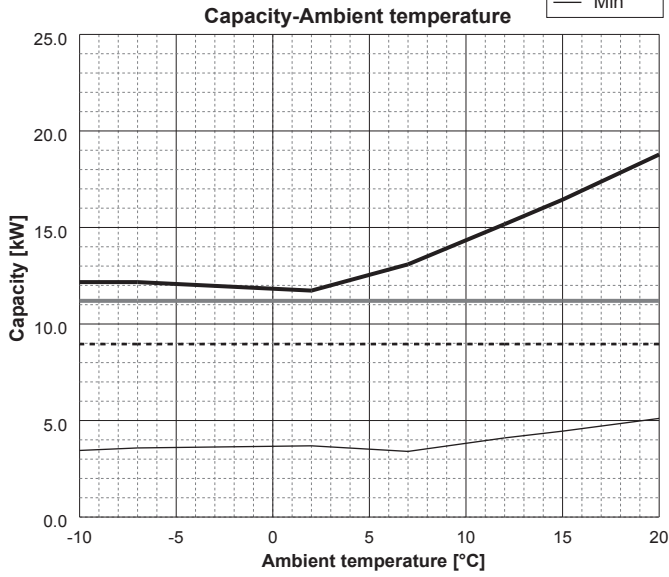

■ Water outlet temperature 45 [°C]

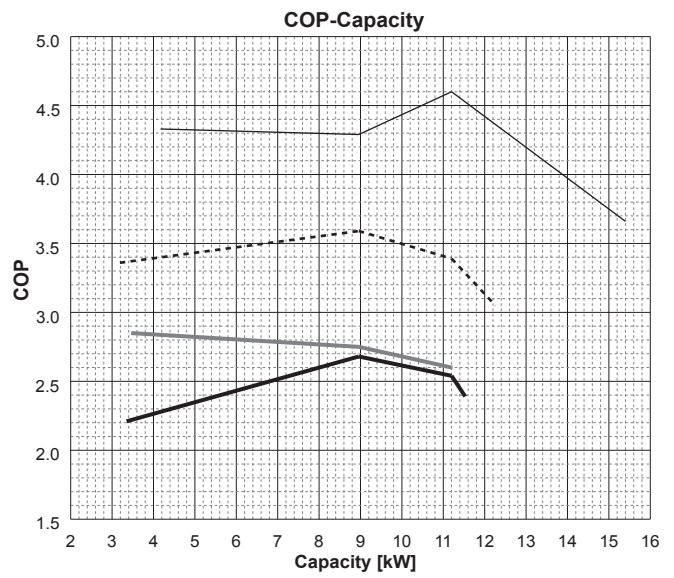
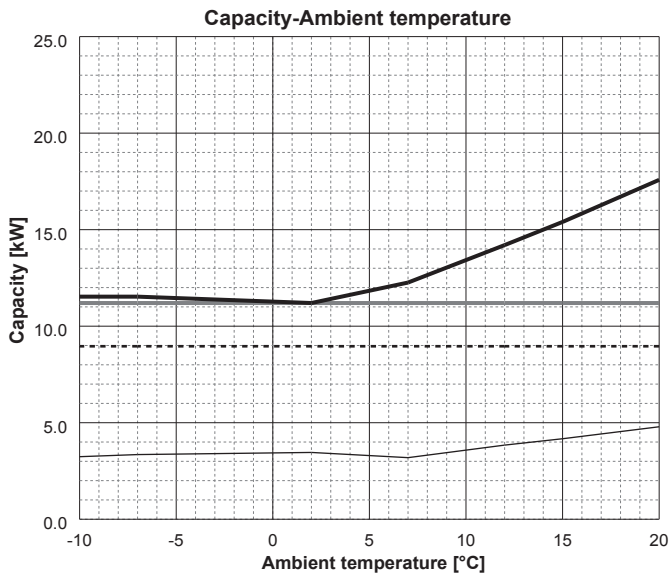

■ Water outlet temperature 55 [°C]

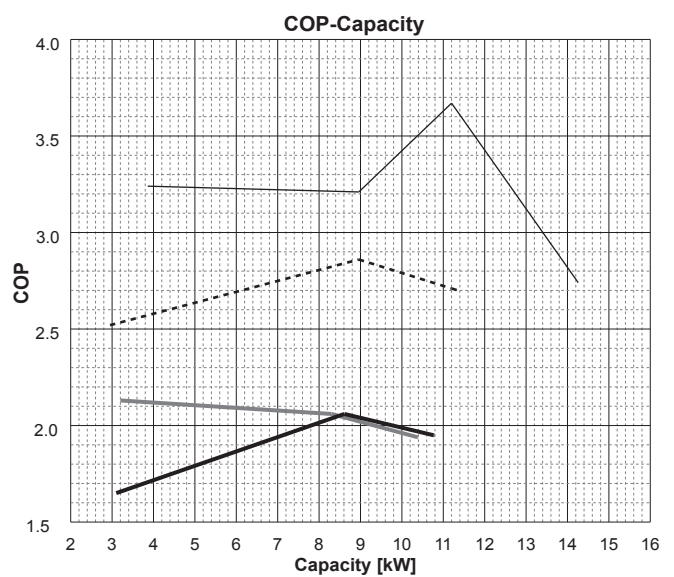
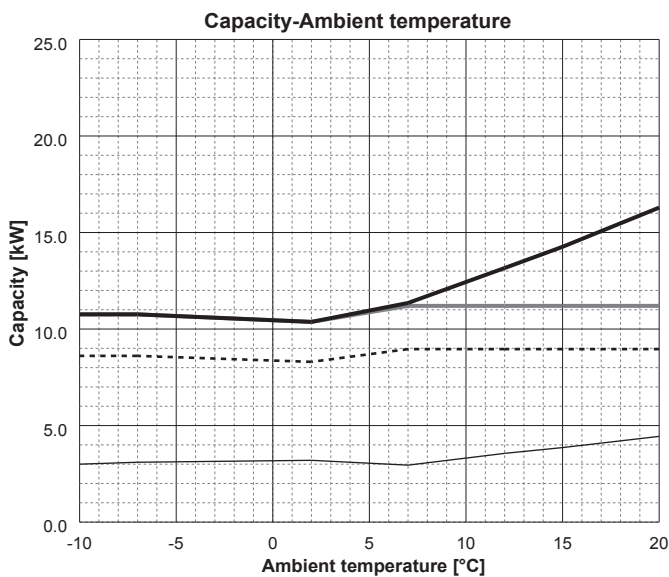

■ Zubadan

Water outlet temperature[°C]		35		45		55	
Ambient temperature[°C]		Capacity	COP	Capacity	COP	Capacity	COP
PUHZ-SHW 80VHA(-BS)	-7	7.18	3.20	7.33	2.46	7.40	1.97
	2	7.54	3.68	7.35	3.00	7.21	2.33
		6.82	4.06	6.72	3.15	6.66	2.46
PUHZ-SHW 112V/YHA(-BS)	7	6.15	4.82	6.03	3.70	5.79	2.90
	-7	7.16	3.18	7.31	2.45	7.38	1.96
		7.52	3.66	7.33	2.99	7.19	2.32
PUHZ-SHW 140YHA(-BS)	2	6.80	4.04	6.70	3.13	6.64	2.45
	7	6.13	4.80	6.01	3.68	5.77	2.89
		7.14	3.18	7.29	2.44	7.36	1.96
PUHZ-SHW 230YKA2	2	7.50	3.65	7.31	2.98	7.17	2.31
	7	6.79	4.03	6.69	3.13	6.63	2.44
		6.12	4.79	6.00	3.67	5.76	2.88
PUHZ-SHW 80V/YAA(-BS)	-7	16.68	2.95	19.41	2.37	20.98	2.13
	2	13.20	3.45	13.04	2.59	12.91	2.27
		12.49	3.55	12.22	2.73	12.00	2.33
PUHZ-SHW 112V/YAA(-BS)	7	11.43	4.31	13.94	3.17	15.42	2.50
	INJ -7	8.00	3.48	8.00	2.68	8.00	2.02
		4.95	3.32	4.78	2.62	4.59	2.07
PUHZ-SHW 112V/YAA(-BS)	2	8.00	3.55	7.73	2.80	7.42	2.21
		6.81	3.99	6.58	3.15	6.32	2.48
	7	6.81	4.64	6.58	3.67	6.32	2.89
PUHZ-SHW 112V/YAA(-BS)	INJ -7	11.20	3.34	11.2	2.54	10.76	1.95
		4.94	3.31	4.77	2.61	4.59	2.06
	2	8.96	3.41	8.65	2.69	8.32	2.12
PUHZ-SHW 112V/YAA(-BS)	7	6.80	3.98	6.57	3.14	6.31	2.48
		6.80	4.63	6.57	3.66	6.31	2.88

INJ : This icon means injection circuit is active.

■ Inverter multi In case of ATW unit single connection

Water outlet temperature[°C]		35		45		55	
Ambient temperature[°C]		Capacity	COP	Capacity	COP	Capacity	COP
PUMY-P 112/125/140 V/YKM(E)3(-BS)	-7	5.95	2.84	6.40	2.21	—	—
	2	6.14	3.14	6.18	2.61	6.39	1.86
		5.17	3.33	5.15	2.87	5.39	1.95
7	8.50	4.37	8.30	3.35	8.18	2.50	

- PUAZ-SW100/120VHA(-BS)
- PUAZ-SW100/120YHA(-BS)
- PUAZ-SW100VAA(-BS)
- PUAZ-SW100YAA(-BS)

- PUAZ-SHW80/112VHA(-BS)
- PUAZ-SHW112/140YHA(-BS)
- PUAZ-SHW80/112VAA(-BS)
- PUAZ-SHW80/112YAA(-BS)

Outdoor unit

<Cooling>

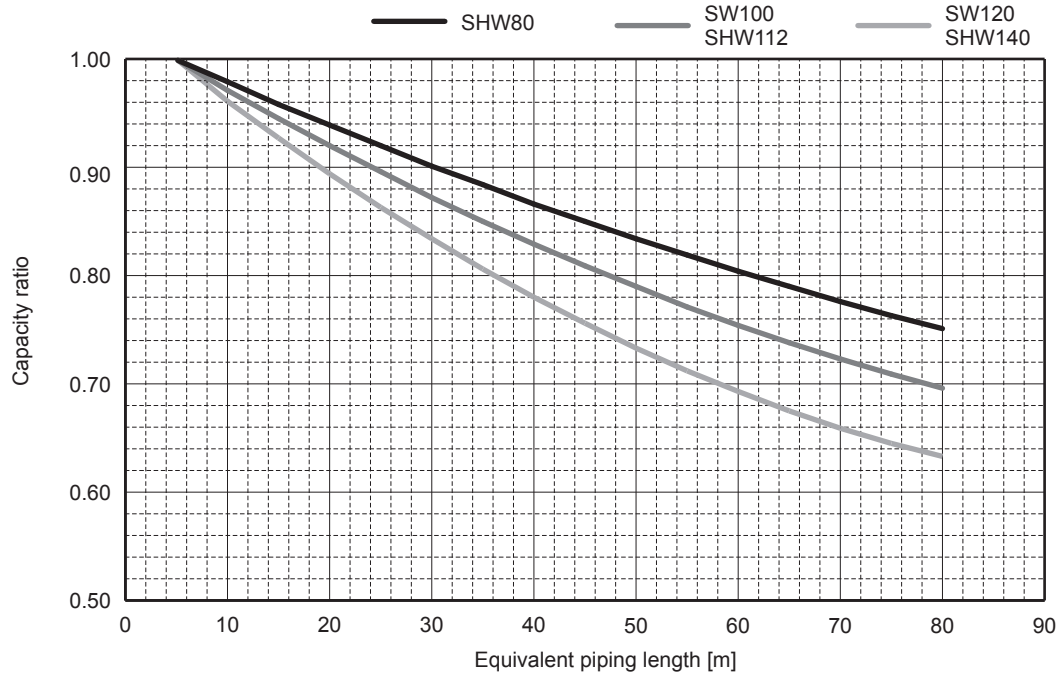

<Heating>

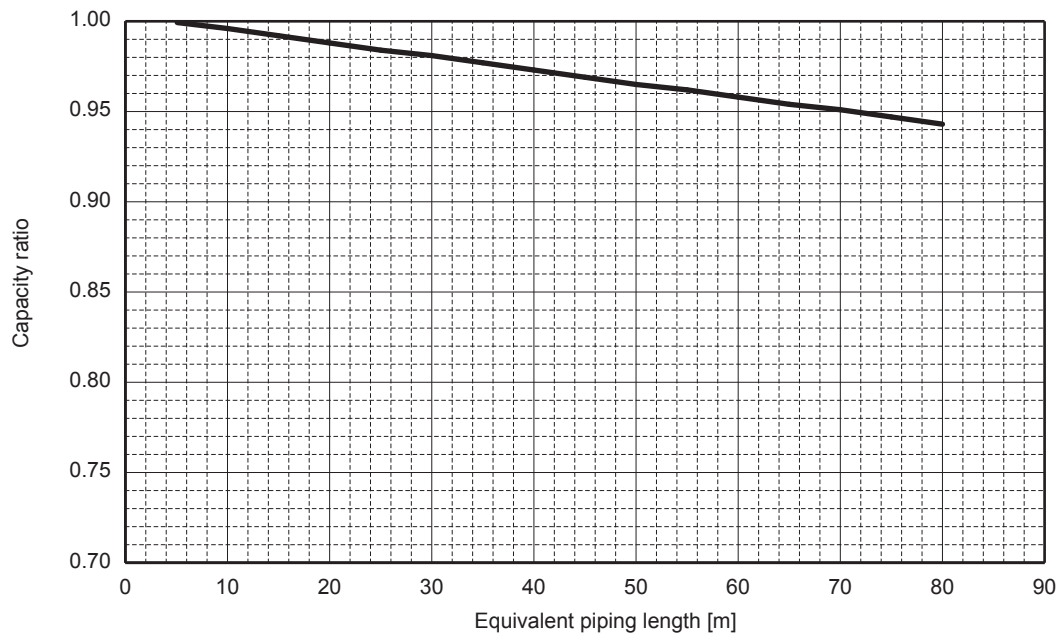

Outdoor unit

PUHZ-SHW230YKA2

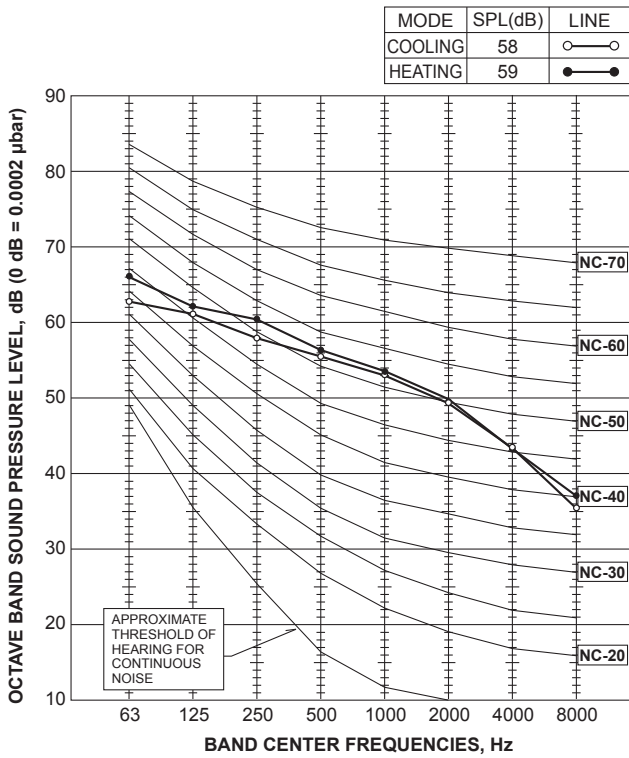

PUHZ-SHW80VAA(-BS) PUHZ-SHW80YAA(-BS)

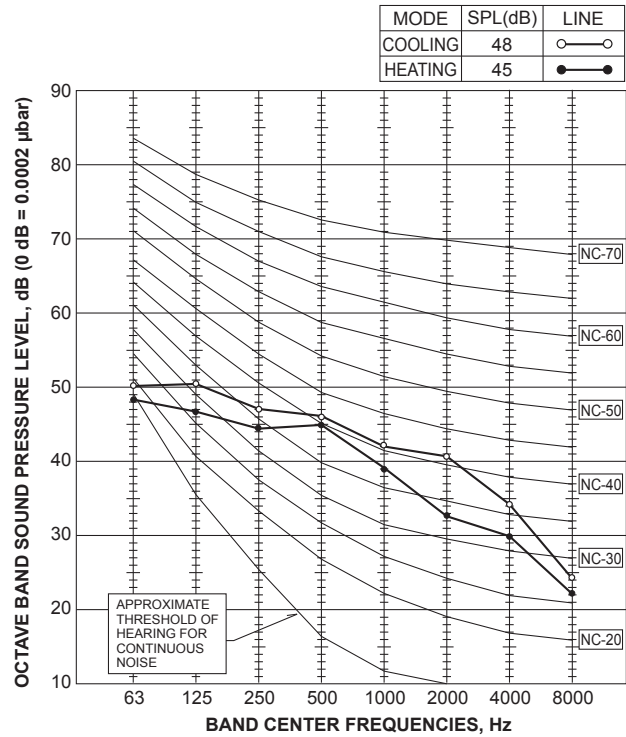

PUHZ-SHW112VAA(-BS) PUHZ-SHW112YAA(-BS)

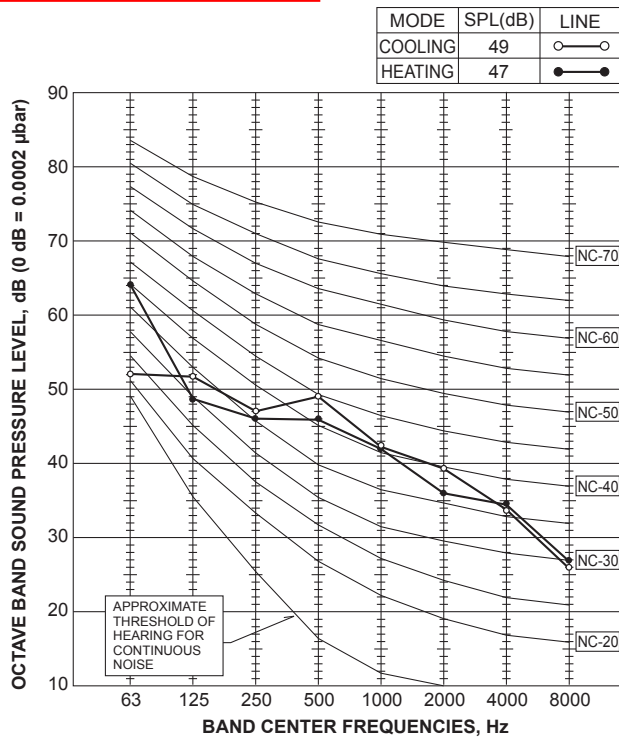

<Notes>

- 1) Sound data is taken when the system is running stably.
- 2) Relatively large noise could be heard transiently in the case 4-way valve, or LEV operates.

PUHZ-SHW80/112VAA(-BS), PUHZ-SHW80/112YAA(-BS)

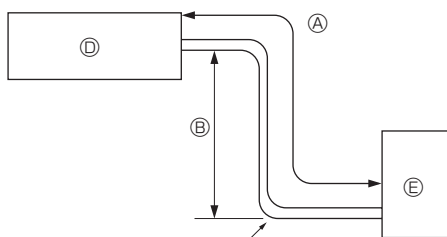

Fig. 4-19

(mm)

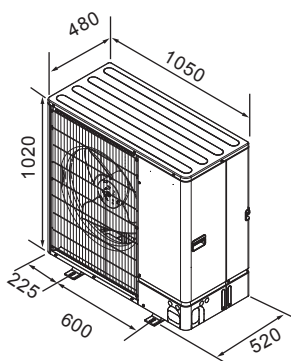

Fig. 4-20

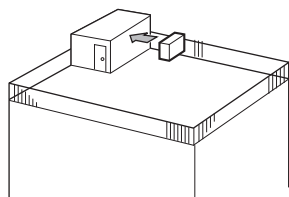

Fig. 4-21

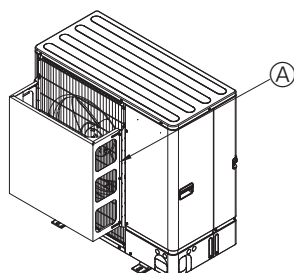

Fig. 4-22

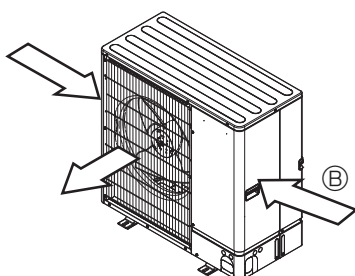

Fig. 4-23

Refrigerant pipe (Fig. 4-19)

- ▶ Check that the difference between the heights of the indoor and outdoor units, the length of refrigerant pipe, and the number of bends in the pipe are within the limits shown below.

Model	Ⓐ Pipe length (one way)	Ⓑ Height difference	Ⓒ Number of bends (one way)
SHW80, 112	2 m - 75 m	Max. 30 m	Max. 15

- Height difference limitation is defined regardless of which unit, indoor or outdoor, is positioned higher.

- Ⓓ Indoor unit
- Ⓔ Outdoor unit

Choosing the outdoor unit installation location

- Avoid locations exposed to direct sunlight or other sources of heat.
- Select a location from which noise emitted by the unit will not inconvenience neighbors.
- Select a location permitting easy wiring and pipe access to the power source and indoor unit.
- Avoid locations where combustible gases may leak, be produced, flow, or accumulate.
- Note that water may drain from the unit during operation.
- Select a level location that can bear the weight and vibration of the unit.
- Avoid locations where the unit can be covered by snow. In areas where heavy snow fall is anticipated, special precautions such as raising the installation location or installing a hood on the air intake must be taken to prevent the snow from blocking the air intake or blowing directly against it. This can reduce the airflow and a malfunction may result.
- Avoid locations exposed to oil, steam, or sulfuric gas.
- Use the transportation handles of the outdoor unit to transport the unit. If the unit is carried from the bottom, hands or fingers may be pinched.

Outline dimensions (Outdoor unit) (Fig. 4-20)

Ventilation and service space

(1) Windy location installation

When installing the outdoor unit on a rooftop or other location unprotected from the wind, situate the air outlet of the unit so that it is not directly exposed to strong winds. Strong wind entering the air outlet may impede the normal airflow and a malfunction may result.

The following shows three examples of precautions against strong winds.

- ① Face the air outlet towards the nearest available wall about 35 cm away from the wall. (Fig. 4-21)
- ② Install an optional air guide if the unit is installed in a location where strong winds from a typhoon, etc. may directly enter the air outlet. (Fig. 4-22)
 - Ⓐ Air outlet guide
- ③ Position the unit so that the air outlet blows perpendicularly to the seasonal wind direction, if possible. (Fig. 4-23)
 - Ⓑ Wind direction

(2) When installing a single outdoor unit (Refer to the next page)

Minimum dimensions are as follows, except for Max., meaning Maximum dimensions, indicated. Refer to the figures for each case.

- ① Obstacles at rear only (Fig. 4-24)
- ② Obstacles at rear and above only (Fig. 4-25)
 - Do not install the optional air outlet guides for upward airflow.
- ③ Obstacles at rear and sides only (Fig. 4-26)
- ④ Obstacles at front only (Fig. 4-27)
- ⑤ Obstacles at front and rear only (Fig. 4-28)
- ⑥ Obstacles at rear, sides, and above only (Fig. 4-29)
 - Do not install the optional air outlet guides for upward airflow.

(3) When installing multiple outdoor units (Refer to the next page)

Leave 50 mm space or more between the units.

Refer to the figures for each case.

- ① Obstacles at rear only (Fig. 4-30)
- ② Obstacles at rear and above only (Fig. 4-31)
 - No more than 3 units must be installed side by side. In addition, leave space as shown.
 - Do not install the optional air outlet guides for upward airflow.
- ③ Obstacles at front only (Fig. 4-32)
- ④ Obstacles at front and rear only (Fig. 4-33)
- ⑤ Single parallel unit arrangement (Fig. 4-34)
 - * When using an optional air outlet guide installed for upward airflow, the clearance is 500 mm or more.
- ⑥ Multiple parallel unit arrangement (Fig. 4-35)
 - * When using an optional air outlet guide installed for upward airflow, the clearance is 1000 mm or more.
- ⑦ Stacked unit arrangement (Fig. 4-36)
 - The units can be stacked up to two units high.
 - No more than 2 stacked units must be installed side by side. In addition, leave space as shown.

UNIT : mm

Outdoor unit

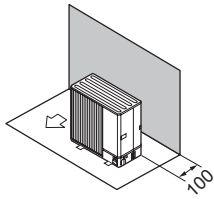

Fig. 4-24

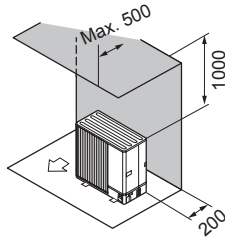

Fig. 4-25

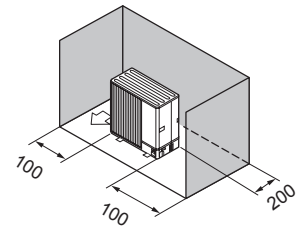

Fig. 4-26

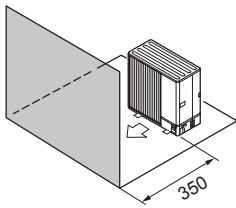

Fig. 4-27

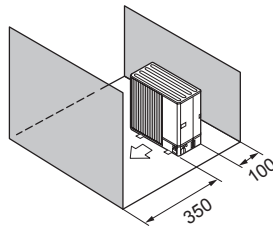

Fig. 4-28

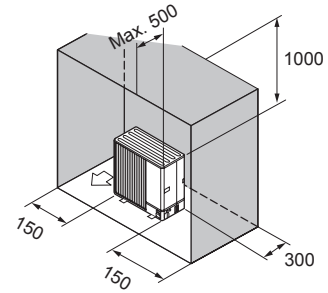

Fig. 4-29

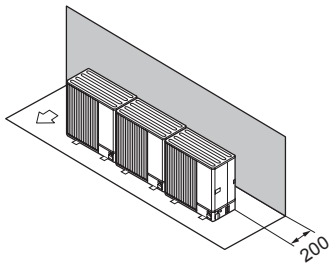

Fig. 4-30

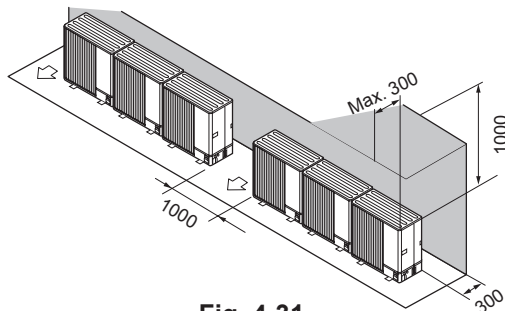

Fig. 4-31

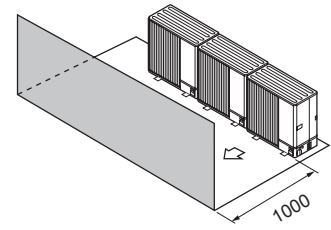

Fig. 4-32

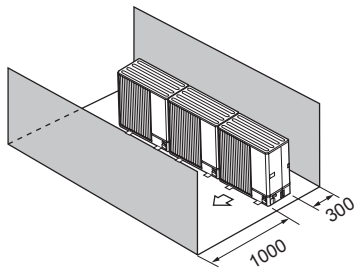

Fig. 4-33

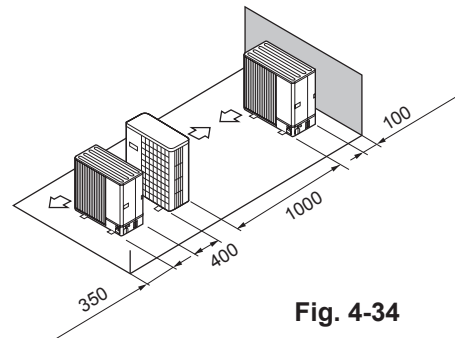

Fig. 4-34

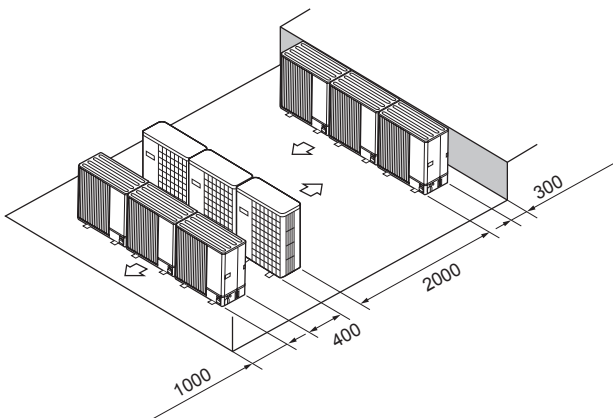

Fig. 4-35

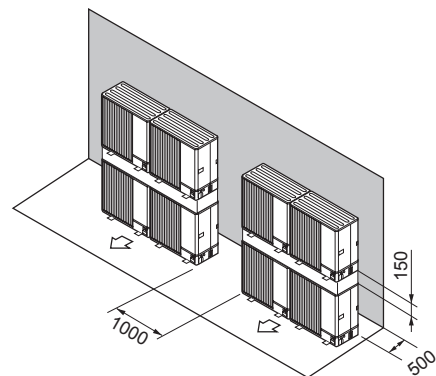

Fig. 4-36

4.1 Water Quality and System Preparation

■ General

- The water in both primary and sanitary circuit should be clean and with pH value of 6.5-8.0
- The followings are the maximum values;
 - Calcium: 100mg/L, Ca hardness: 250mg/L
 - Chlorine: 100mg/L, Copper: 0.3mg/L
- Other constituents should be to European Directive 98/83 EC standards.
- In known hard water areas, to prevent/minimise scaling, it is beneficial to restrict the routine stored water temperature (DHW max. temp.) to 55°C.

■ Anti-Freeze

Anti-freeze solutions should use propylene glycol with a toxicity rating of Class 1 as listed in Clinical Toxicology of Commercial Products, 5th Edition.

Note:

1. Ethylene glycol is toxic and should NOT be used in the primary water circuit in case of any cross-contamination of the potable circuit.
2. For 2-zone valve ON/OFF control, propylene glycol should be used.

■ New Installation (primary water circuit)

- Before connecting outdoor unit, thoroughly cleanse pipework of building debris, solder etc using a suitable chemical cleansing agent.
- Flush the system to remove chemical cleanser.
- For all packaged model systems add a combined inhibitor and anti-freeze solution to prevent damage to the pipework and system components.
- For split model systems the responsible installer should decide if anti-freeze solution is necessary for each site's conditions. Corrosion inhibitor however should always be used.

■ Existing Installation (primary water circuit)

- Before connecting outdoor unit the existing heating circuit MUST be chemically cleansed to remove existing debris from the heating circuit.
- Flush the system to remove chemical cleanser.
- For all packaged model systems, and the split model without booster heater, add a combined inhibitor and anti-freeze solution to prevent damage to the pipework and system components.
- For split model systems the responsible installer should decide if anti-freeze solution is necessary for each site's conditions. Corrosion inhibitor however should always be used.

When using chemical cleansers and inhibitors always follow manufacturer's instructions and ensure the product is appropriate for the materials used in the water circuit

4.2 Water Pipe Work

Note: Prevent the field piping from straining the piping on the cylinder unit/hydrobox by fixing it to a wall or applying other methods.

■ Hot Water Pipework

The function of the following safety components of the cylinder unit/hydrobox should be checked on installation for any abnormalities;

- Pressure relief valve
- Expansion vessel pre-charge (gas charge pressure)

The instruction on the following pages regarding safe discharge of hot water from Safety devices should be followed carefully.

- The pipework will become very hot, so should be insulated to prevent burns.
- When connecting pipework, ensure that no foreign objects such as debris or the like do not enter the pipe.

■ Hydraulic Filter Work (ONLY EHPX series)

Install a hydraulic filter or strainer (local supply) at the water intake ("Pipe E" in Table 2.1.1)

■ Negative pressure prevention (ONLY CYLINDER unit)

To prevent negative pressure effecting DHW tank, installer should install appropriate pipework or use appropriate devices.

■ Pipework Connections (Except for EHSE/ERSE series)

Connections to the cylinder unit / hydrobox should be made using the 22 mm or 28 mm compression as appropriate. (except for ERSC series) Do not over-tighten compression fittings as this will lead to deformation of the olive ring and potential leaks.

Note: To weld the pipes in the field, cool the pipes on the cylinder unit / hydrobox using wet towel etc.

ERSC series have G1 (male) thread connections.

■ Minimum amount of water required in the space heating / cooling circuit

Outdoor heat pump unit		Minimum water quantity [L]
Packaged model	PUHZ-W50	29
	PUHZ-W85	37
	PUHZ-W112	48
	PUHZ-HW112	48
	PUHZ-HW140	60
Split model	SUHZ-SW45	17
	PUHZ-SW50	22
	PUHZ-FRP71	32
	PUHZ-SW75	32
	PUHZ-SW100	43
	PUHZ-SW120	54
	PUHZ-SW160	69
	PUHZ-SW200	86
	PUHZ-SHW80	34
	PUHZ-SHW112	48
	PUHZ-SHW140	60
	PUHZ-SHW230	99
	PUMY-P112	80
PUMY-P125	80	
PUMY-P140	80	

Note:

For 2-zone temperature control system, the value in the table above excludes the amount of stored water in zone 2.

■ Pipework Connections (EHSE/ERSE series)

Connections to the hydrobox should be made using the G1-1/2 nut as appropriate. (The hydrobox has G1-1/2 (male) thread connections.) Please apply a gasket nut to leak water.

Use two wrenches to tighten piping connection (see <Figure 4.2.1>).

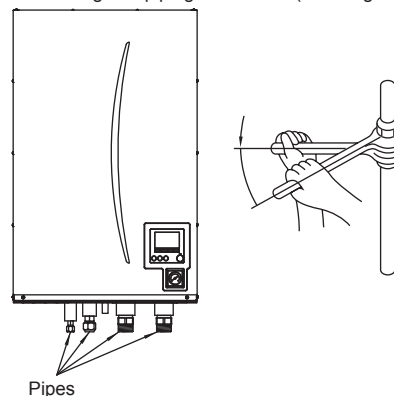

<Figure 4.2.1>

■ Insulation of Pipework

- All exposed water pipework should be insulated to prevent unnecessary heat loss and condensation. To prevent condensate entering the hydrobox, the pipework and connections at the top of the cylinder unit / hydrobox should be carefully insulated.
- Cold and hot water pipework should not be run close together where possible, to avoid unwanted heat transfer.
- Pipework between outdoor heat pump unit and cylinder unit / hydrobox should be insulated with suitable pipe insulation material with a thermal conductivity of ≤ 0.04 W/m.K.

Water Circulation Pump Characteristics (Except for EHSE/ERSE series)

1. Primary circuit

Pump speed can be selected by main remote controller setting (see Section 4.3). Adjust the pump speed setting so that the flow rate in the primary circuit is appropriate for the outdoor unit installed (see Table 4.2.1). It may be necessary to add an additional pump to the system depending on the length and lift of the primary circuit. For outdoor unit model not listed in the <Table 4.2.1>, refer to Water flow rate range in the specification table of outdoor unit Data Book. In such case, make sure that the flow rate is greater than 7.1 L/min and less than 27.7 L/min.

<Second pump >

If a second pump is required for the installation please read the following carefully. If a second pump is used in the system it can be positioned in 2 ways. The position of the pump influences which terminal of the FTC the signal cable should be wired to. If the additional pump(s) have current greater than 1A please use appropriate relay. Pump signal cable can either be wired to TBO.1 1-2 or CNP1 but not both.

Option 1 (Space heating/cooling only)

If the second pump is being used for the heating circuit only then the signal cable should be wired to TBO.1 terminals 3 and 4 (OUT2). In this position the pump can be run at a different speed to the hydrobox's in-built pump.

Option 2 (Primary circuit DHW and space heating/cooling)

If the second pump is being used in the primary circuit between the hydrobox and the outdoor unit (Package system ONLY) then the signal cable should be wired to TBO.1 terminals 1 and 2 (OUT1). In this position the pump speed **MUST** match the speed of the hydrobox's in-built pump.

Note: Refer to 3.1.3 (cylinder) or 3.2.4 (hydrobox) Connecting inputs/outputs.

Outdoor heat pump unit		Water flow rate range [L/min]
Packaged model	PUHZ-W50	7.1 - 14.3
	PUHZ-W85	10.0 - 25.8
	PUHZ-W112	14.4 - 27.7
	PUHZ-HW112	14.4 - 27.7
	PUHZ-HW140	17.9 - 27.7
Split model	SUHZ-SW45	7.1 - 12.9
	PUHZ-SW50	7.1 - 17.2
	PUHZ-FRP71	11.5 - 22.9
	PUHZ-SW75	9.5 - 22.9
	PUHZ-SW100	14.4 - 27.7
	PUHZ-SW120	20.1 - 27.7
	PUHZ-SHW80	10.2 - 22.9
	PUHZ-SHW112	14.4 - 27.7
	PUHZ-SHW140	17.9 - 27.7
	PUMY-P112	17.9 - 27.7
	PUMY-P125	17.9 - 27.7
PUMY-P140	17.9 - 27.7	

<Table 4.2.1>

* If the water flow rate is less than 7.1 L/min, the flow rate error will be activated.

If the water flow rate exceeds 27.7 L/min, the flow speed will be greater than 1.5 m/s, which could erode the pipes.

2. Sanitary circuit

Default setting: Speed 2

DHW circulation pump **MUST** be set to speed 2.

Water Circulation Pump Characteristics (EHSE/ERSE series)

Pump speed can be selected by main remote controller setting (see Section 4.3). Adjust the pump speed setting so that the flow rate in the primary circuit is appropriate for the outdoor unit installed (see Table 4.2.2). It may be necessary to add an additional pump to the system depending on the length and lift of the primary circuit.

<Second pump>

If a second pump is required for the installation please read the following carefully.

If a second pump is used in the system it can be positioned in 2 ways.

The position of the pump influences which terminal of the FTC the signal cable should be wired to. If the additional pump(s) have current greater than 1A please use appropriate relay. Pump signal cable can either be wired to TBO.1 1-2 or CNP1 but not both.

Option 1 (Space heating/cooling only)

If the second pump is being used for the heating circuit only then the signal cable should be wired to TBO.1 terminals 3 and 4 (OUT2). In this position the pump can be run at a different speed to the hydrobox's in-built pump.

Option 2 (Primary circuit DHW and space heating/cooling)

If the second pump is being used in the primary circuit between the hydrobox and the outdoor unit (Package system ONLY) then the signal cable should be wired to TBO.1 terminals 1 and 2 (OUT1). In this position the pump speed **MUST** match the speed of the hydrobox's in-built pump.

Note: Refer to 3.2.4 (hydrobox) Connecting inputs/outputs.

Outdoor heat pump unit	Water flow rate range [L/min]
PUHZ-SW160	23.0 - 61.5
PUHZ-SW200	28.7 - 61.5
PUHZ-SHW230	28.7 - 61.5

<Table 4.2.2>

* If the water flow rate is less than 7.1 L/min, the flow rate error will be activated.

* If the water flow rate exceeds 61.5 L/min, the flow speed will be greater than 1.5 m/s, which could erode the pipes.

■ Combination performance (Split type)

			Cylinder unit										Hydrobox													
			ERST20C-VM2C	ERST20C-MEC	EHST20C-VM2C	EHST20C-VM6C	EHST20C-VM9C	EHST20C-TM9C	EHST20C-VM2EC	EHST20C-VM6EC	EHST20C-VM9EC	EHST20C-MEC	EHST20C-MHCW	ERSC-VM2C	ERSC-MEC	EHSC-VM2C	EHSC-VM6C	EHSC-VM9C	EHSC-TM9C	EHSC-VM2EC	EHSC-VM6EC	EHSC-VM9EC	EHSC-MEC			
Outdoor unit			PUHZ-SHW80VHA(-BS)																							
Heating A7/W35	Capacity	kW																				8.00				
	COP	-																				4.65				
	Power input(*)	kW																				1.72				
Heating A7/W45	Capacity	kW																				8.00				
	COP	-																				3.42				
	Power input(*)	kW																				2.34				
Heating A2/W35	Capacity	kW																				8.00				
	COP	-																				3.55				
	Power input(*)	kW																				2.25				
Cooling A35/W7	Capacity	kW	7.10																				7.10			
	EER	-	3.31																					3.31		
	Power input(*)	kW	2.15																					2.15		
Cooling A35/W18	Capacity	kW	7.10																					7.10		
	EER	-	4.52																					4.52		
	Power input(*)	kW	1.57																					1.57		
Outdoor unit			PUHZ-SHW112VHA/YHA(-BS)																							
Heating A7/W35	Capacity	kW																				11.20				
	COP	-																				4.46				
	Power input(*)	kW																				2.51				
Heating A7/W45	Capacity	kW																				11.20				
	COP	-																				3.51				
	Power input(*)	kW																				3.20				
Heating A2/W35	Capacity	kW																				11.20				
	COP	-																				3.34				
	Power input(*)	kW																				3.35				
Cooling A35/W7	Capacity	kW	10.00																					10.00		
	EER	-	2.83																					2.83		
	Power input(*)	kW	3.53																					3.53		
Cooling A35/W18	Capacity	kW	10.00																					10.00		
	EER	-	4.74																					4.74		
	Power input(*)	kW	2.11																					2.11		
Outdoor unit			PUHZ-SHW140YHA(-BS)																							
Heating A7/W35	Capacity	kW																				14.00				
	COP	-																				4.22				
	Power input(*)	kW																				3.32				
Heating A7/W45	Capacity	kW																				14.00				
	COP	-																				3.28				
	Power input(*)	kW																				4.27				
Heating A2/W35	Capacity	kW																				14.00				
	COP	-																				2.96				
	Power input(*)	kW																				4.73				
Cooling A35/W7	Capacity	kW	12.50																					12.50		
	EER	-	2.17																					2.17		
	Power input(*)	kW	5.76																					5.76		
Cooling A35/W18	Capacity	kW	12.50																					12.50		
	EER	-	4.26																					4.26		
	Power input(*)	kW	2.93																					2.93		
Outdoor unit			PUHZ-SHW80VAA/YAA(-BS)																							
Heating A7/W35	Capacity	kW																				8.00				
	COP	-																				4.65				
	Power input(*)	kW																				1.72				
Heating A7/W45	Capacity	kW																				8.00				
	COP	-																				3.42				
	Power input(*)	kW																				2.34				
Heating A2/W35	Capacity	kW																				8.00				
	COP	-																				3.55				
	Power input(*)	kW																				2.25				
Cooling A35/W7	Capacity	kW	7.10																					7.10		
	EER	-	3.31																					3.31		
	Power input(*)	kW	2.15																					2.15		
Cooling A35/W18	Capacity	kW	7.10																					7.10		
	EER	-	4.52																					4.52		
	Power input(*)	kW	1.57																					1.57		
Outdoor unit			PUHZ-SHW112VAA/YAA(-BS)																							
Heating A7/W35	Capacity	kW																				11.20				
	COP	-																				4.46				
	Power input(*)	kW																				2.51				
Heating A7/W45	Capacity	kW																				11.20				
	COP	-																				3.42				
	Power input(*)	kW																				3.27				
Heating A2/W35	Capacity	kW																				11.20				
	COP	-																				3.22				
	Power input(*)	kW																				3.48				
Cooling A35/W7	Capacity	kW	10.00																					10.00		
	EER	-	2.83																					2.83		
	Power input(*)	kW	3.53																					3.53		
Cooling A35/W18	Capacity	kW	10.00																					10.00		
	EER	-	4.74																					4.74		
	Power input(*)	kW	2.11																					2.11		

* The pump input value is not included.

Heating A7W35: Heating outside air DB 7°C/WB 6°C, Water outlet temperature 35°C (ΔT=5°C)
 A7W45: Heating outside air DB 7°C/WB 6°C, Water outlet temperature 45°C (ΔT=5°C)
 A2W35: Heating outside air DB 2°C/WB 1°C, Water outlet temperature 35°C (ΔT=5°C)

Cooling A35/W7: Cooling outside air DB 35°C, Water outlet temperature 7°C (ΔT=5°C)
 A35/W18: Cooling outside air DB 35°C, Water outlet temperature 18°C (ΔT=5°C)